

12

COMPLEMENTI

FACTOTUM
★★★★

ACCESSORIES
ACCESSOIRES
ZUBEHÖRE
ACCESORIOS

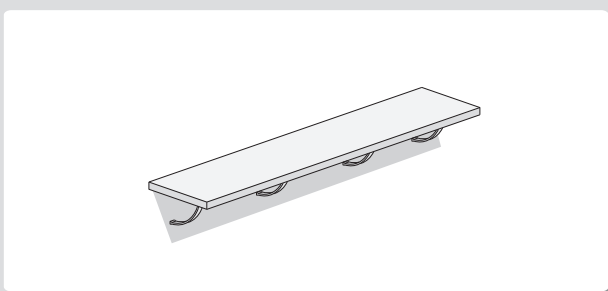
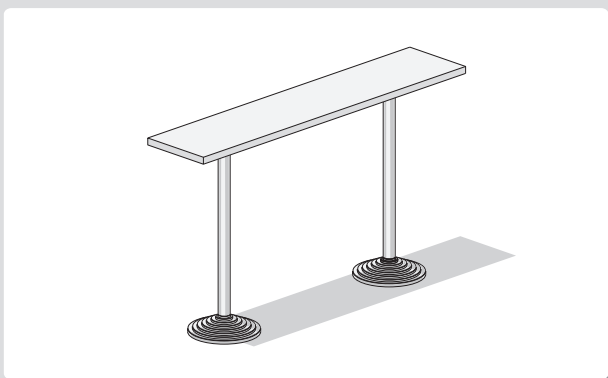
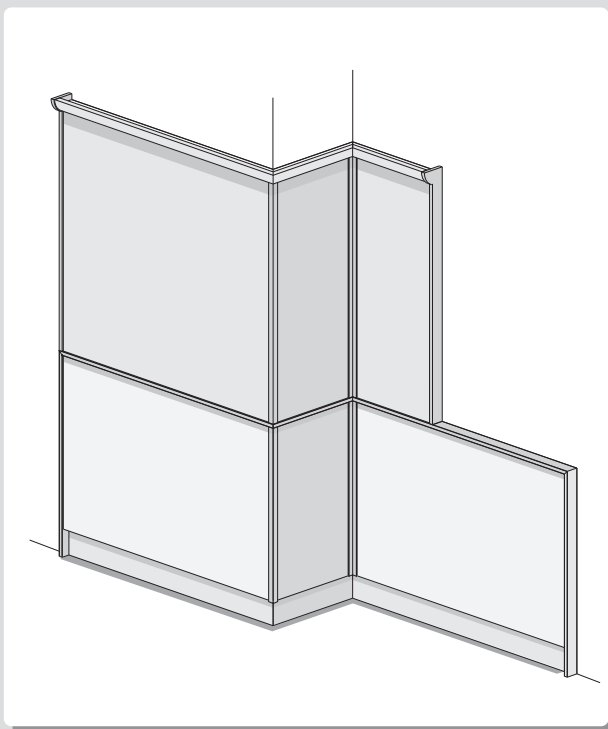

Caratteristiche tecniche

Rivestimento parete disponibile in due altezze, basso (H =1051) alto (H=2350), il sistema e' modulare e permette di realizzare rivestimenti personalizzati nelle diverse estetiche.

Il fondo pennellatura e' in legno impiallacciato verniciato, mentre il profilo i fianchi terminali e il paralume sono in legno massello. Lo zoccolo e' in marmo, personalizzabile con l'estetica del banco.

Technical features

The wall coating is available with two heights, low (H = 1051), high (H = 2350); the system is modular and permits to realize custom-made coatings according to the different designs. The panelling ground is made with painted veneered wood, while the profile, end flanks and light shade are of heartwood. The plinth is made of marble and can be customized according to the counter design.

Caractéristiques techniques

Revêtement paroi disponible en deux hauteurs, bas (H = 1051), haut (H = 2350), le système est modulaire et permet de réaliser revêtements personnalisés suivant les plusieurs esthétiques. Le fond à panneaux est en bois plaqué verni, tandis que le profil, les flancs terminaux et l'abat-jour sont en bois massif. La plinthe est en marbre, à personnaliser selon l'esthétique du comptoir.

Technische Eigenschaften

Wandverkleidung; mit zwei Höhen vorhanden, niedrig (H=1051), hoch (H=2350), Modulsystem um personalisierte Verkleidungen nach den gewählten Ästhetiken zu realisieren.

Der Paneelboden ist aus furniertem, gestrichenem Holz; der Profil, die Endflanken und der Lampenschirm sind aus Kernholz. Der Wandsockel ist aus Marmor und kann nach der Thekenästhetik personalisiert werden.

Características técnicas

Recubrimiento de la pared disponible con dos alturas, baja (H=1051), alta (H= 2350), el sistema es modular y permite realizar revestimientos personalizados con las diferentes estéticas.

El fondo del panel es de madera contrachapada barnizada, mientras que el perfil, los laterales terminales y el portalamparas son de madera maciza. El zócalo es de mármol, personalizable con la estética del mostrador.



GOST STANDARD

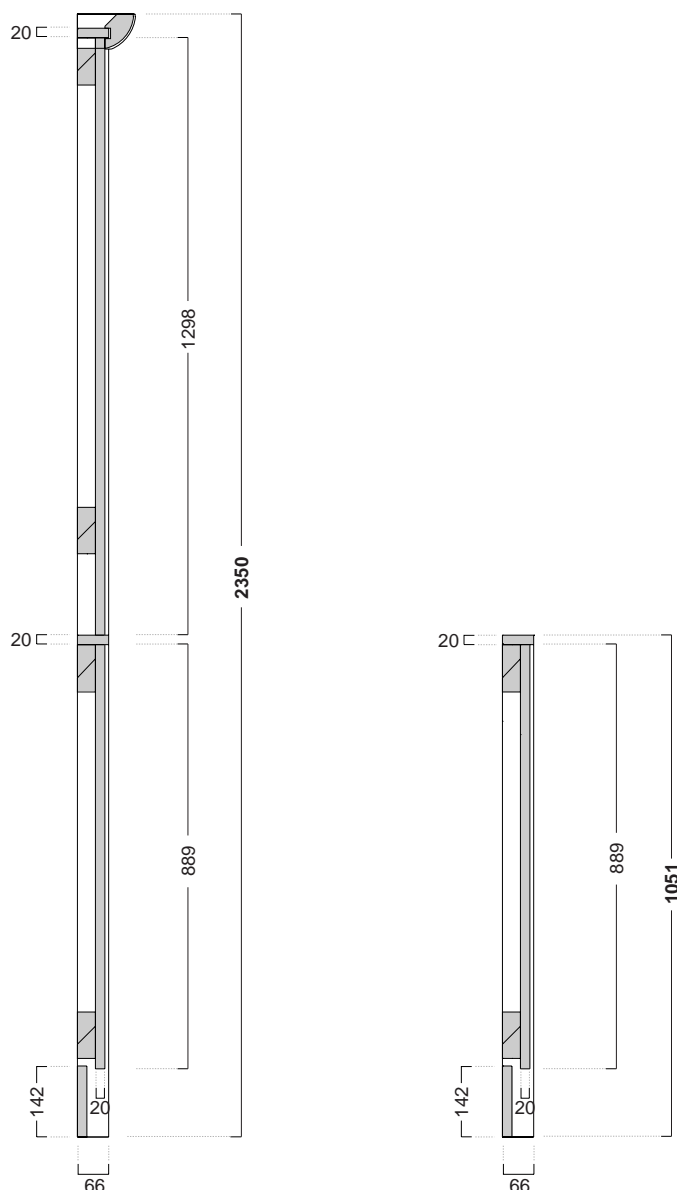

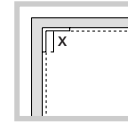
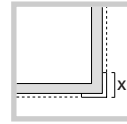
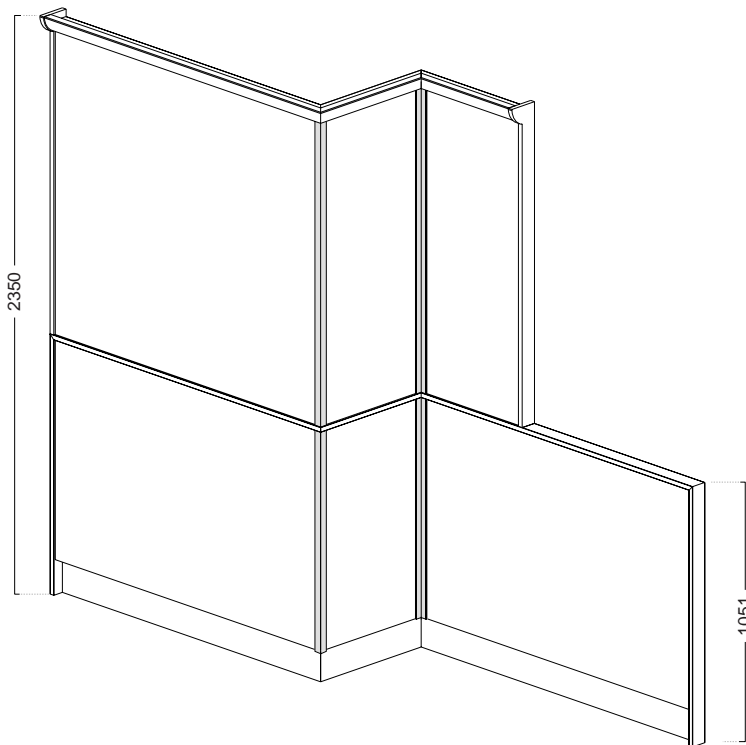

**Angolare finitura
A2/90°**

Finishing angle A2/90°
Finition angle A2/90°
Feinbearbeitungsecke A2/90°
Acabado angular A2/90°

**Angolare finitura
A1/90°**

Finishing angle A1/90°
Finition angle A1/90°
Feinbearbeitungsecke A1/90°
Acabado angular A1/90°

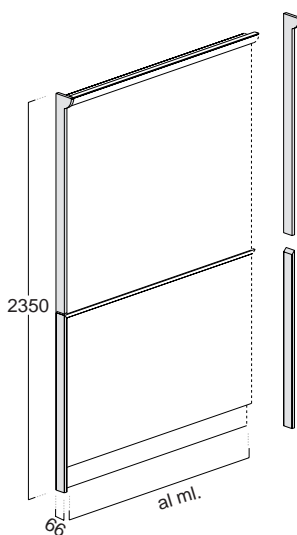

Fianco terminale

End flank
Flanc terminal
Endflanke
Lateral terminal

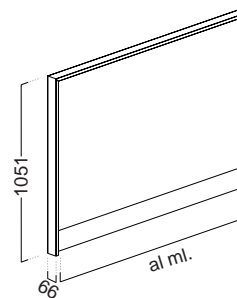

Fianco terminale

End flank
Flanc terminal
Endflanke
Lateral terminal

Caratteristiche tecniche

Fascia battisedia composta da regolo di base in legno koto' da fissare a parete e fascia battisedia di copertura disponibile in legno massello o marmo, il tutto completo di tappi terminali anodizzati colore oro o alluminio. Disponibile con dimensione max. L= 4000, personalizzabile nelle diverse estetiche.

Technical features

Chair board strip consisting of a basic list of kotò wood to be fixed on the wall and covering chair board strip available with heartwood or marble, the whole equipped with anodized end plugs, colours: gold or aluminium. Max. dimension available: L=4000, to be customized according to the various designs.

Caractéristiques techniques

Bande bat-chaise composée par meneau de base en bois kotò a fixer à la paroi et bande bat-chaise de couverture disponible en bois massif ou marbre, tout cela muni de bouchons terminaux anodisés, couleur or ou aluminium. Disponible avec dimension max. L = 4000, à personnaliser suivant les plusieurs esthétiques.

Technische Eigenschaften

Stuhlbrett mit Basenleiste aus kotò Holz für Wandbefestigung und Abdeckstuhlbrett aus Kernholz oder Marmor, alles mit eloxierten Endverschlüsse, Farbe: Gold oder Aluminium.
Max. Mass vorhanden: L=4000, entsprechend den verschiedenen Ästhetiken personalisiert..

Características técnicas

Borde a la altura de la silla compuesto por una base de madera kotó para fijar a la pared y borde de cobertura disponible en madera maciza o en mármol, todo con tapones terminales anodizados color oro o aluminio.
Disponible con medida máxima 4000, personalizable con las diferentes estéticas.

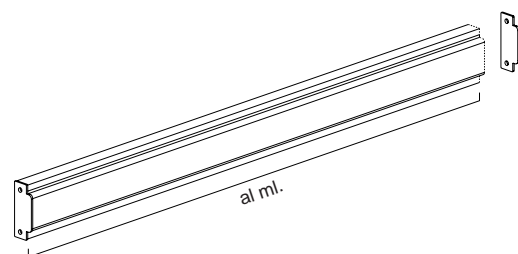
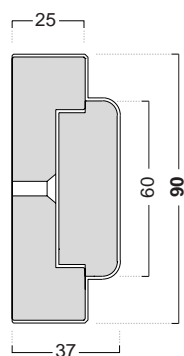

Caratteristiche tecniche

Mensola snack disponibile nelle versioni con basamento, realizzato in fusione di lega in alluminio, o con reggimensola da fissare a parete. Il piano realizzato in legno koto' sp. 4cm e' disponibile con misure a partire da cm 100 fino a cm 400, se necessario può essere canalizzato per creare composizioni lineari o curvilinee.

La mensola può essere verniciata a campione secondo l'estetica prescelta.

Technical features

Snack shelf available in the versions with base made of aluminium alloy casting or with shelf-support to be fixed on the wall. The surface realized with cm.4 deep kotò wood is available in the sizes from 100 cm. to 400 cm; if necessary, it can be canalized to create either linear or curvilinear compositions, the shelf can be painted according to standard colours and the chosen design.

Caractéristiques techniques

Etagère Snack disponible dans les versions avec base réalisée en fusion d'alliage d'aluminium, ou avec appui-étagère a fixer à la paroi. Le plan réalisé en bois kotò, épaisseur 4 cm., est disponible avec mesures à partir de cm. 100 jusqu'à cm 400, si nécessaire, il peut être canalisé pour créer des compositions linéaires ou curvilignes. L'étagère peut être vernie selon les couleurs-échantillons suivant l'esthétique choisie.

Technische Eigenschaften

Snack Konsole in den Versionen mit Untersatz vorhanden – Untersatz aus Schmelzen von Aluminiumlegierung – oder mit Konsolenständer für Wandbefestigung. Die Platte aus kotò Holz, 4 cm. tief, ist in den Massen von 100 cm. bis zu 400 cm. vorhanden, bei Bedarf kann sie kanalisiert werden um lineare oder krummlinige Aufbauten zu realisieren. Die Konsole kann entsprechend Standardfarben und gewählter Ästhetik gestrichen werden.

Características técnicas

Repisa snack disponible en las versiones con base, realizado en fusión de liga de aluminio, o con portarepisa para fijar a la pared. El plano realizado en madera kotó con grosor de 4 cm. está disponible con medidas a partir de cm 100 hasta cm 400, si es necesario se puede unir con otros módulos para realizar composiciones lineares o con curvas. La repisa puede ser barnizada según la estética elegida.



GOST STANDARD

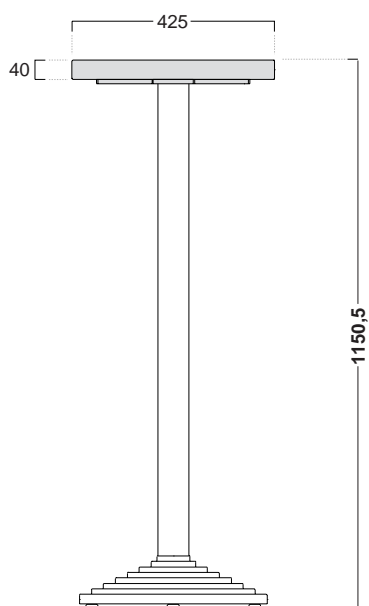

Mensola snack a muro

- Wall shelf • Etagère à mur
- Wandkonsole • Repisa para pared

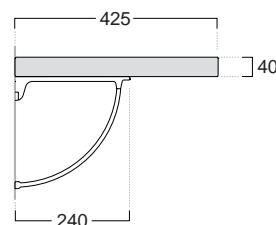

100

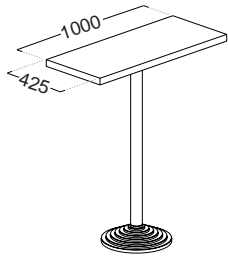

250/300

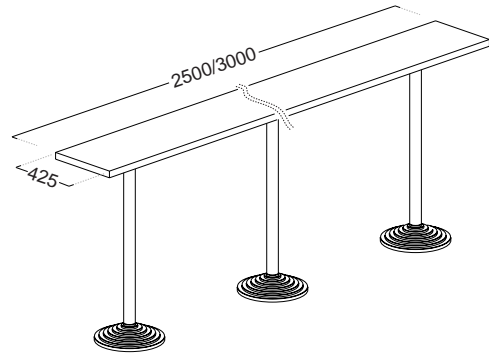

150/200

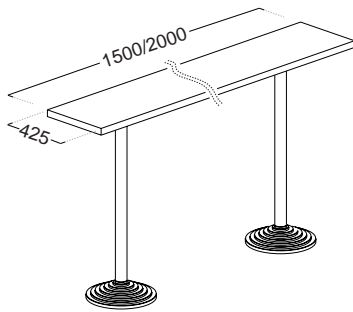

350/400

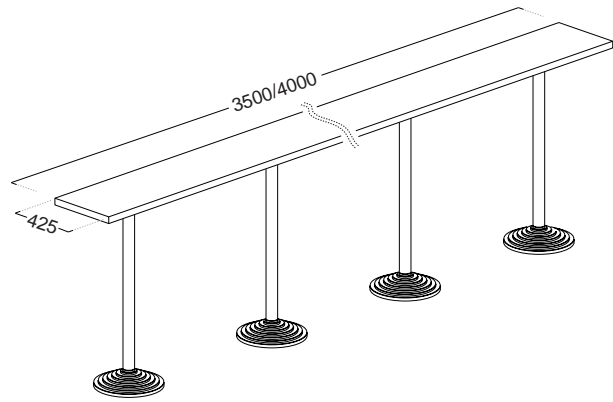

A 1/45°

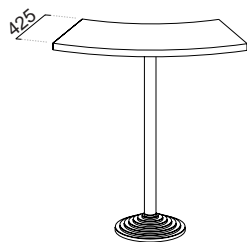

A 2/45°

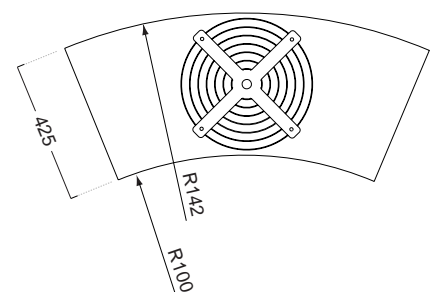
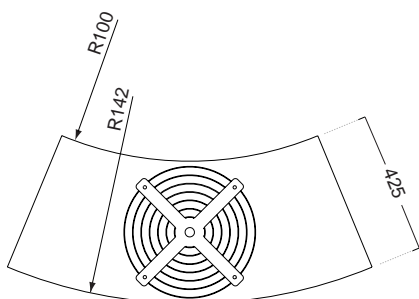
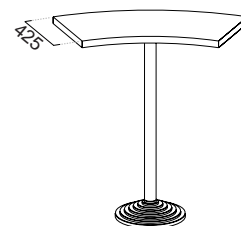

100

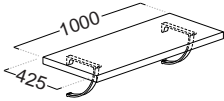

300

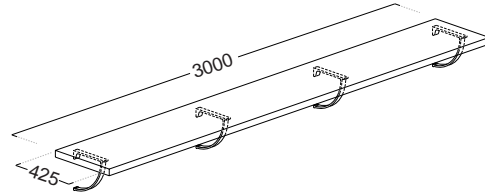

150

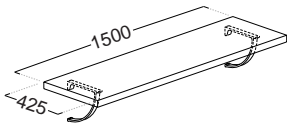

350

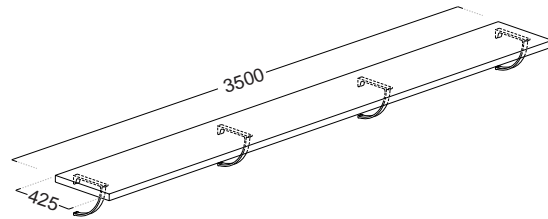

200

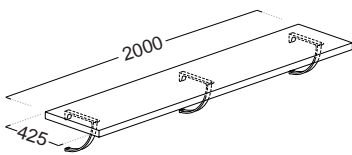

400

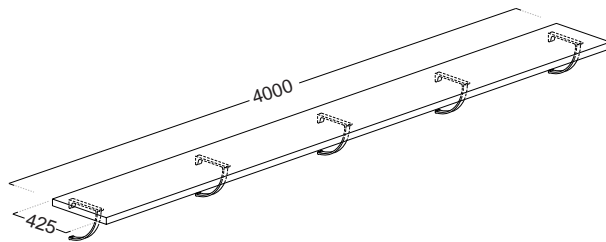

250

